

- Compression load cell, selfcentering column
- 1000 divisions OIML R60 class C
- Available in **ATEX** version (optional)  
Zone 0-1-2 (gas) and 20-21-22 (dust)
- Simple to install
- Stainless Steel construction
- Hermetically welded, protection class  
IP 68 (EN 60529) and IP 69K (ISO 20653)
- Pre-corner adjustment optimized for multi-  
cell systems
- Lightning protection
- Applications: High capacity weighing  
systems

- Schwerlastwägezelle, selbstzentrierend
- 1000 Teile OIML R60 Klasse C
- Erhältlich in **ATEX** -Ausführung (optional)  
Zone 0-1-2 (Gas) und 20-21-22 (Staub)
- Einfache Montage
- Ausführung in Edelstahl
- Hermetisch dicht verschweißt Schutzart  
IP 68 (EN 60529) und IP 69K (ISO 20653)
- Abgeglichener Ausgang für problemlose  
Parallelschaltung
- Blitzschutz
- Applikationen: Schwerlastwaagen

Model Modell	Nominal capacity Nennlast Ln	Accuracy class Genauigkeitsklasse n. OIML	Minimum division Kleinster Teilungswert vmin	Safe load limit Grenzlast 150 % Ln	Breaking load Bruchlast
740 100 t	100 t	1000	15 kg	150 t	350 t
740 200 t	200 t	1000	30 kg	300 t	450 t
740 400 t	400 t	1000	60 kg	600 t	1200 t
740 600 t	600 t	1000	90 kg	900 t	1800 t



**MODEL 740 +** ACC. **74904** (100 t...200 t)  
 ACC. **74911** (400 t)  
 ACC. **74912** (600 t)

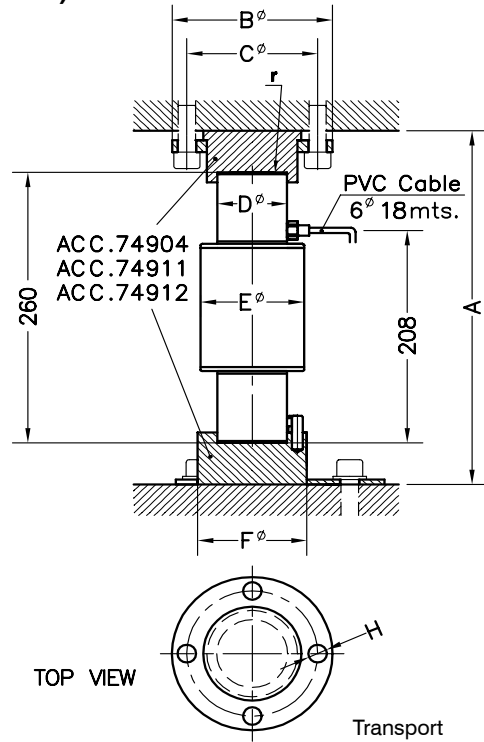
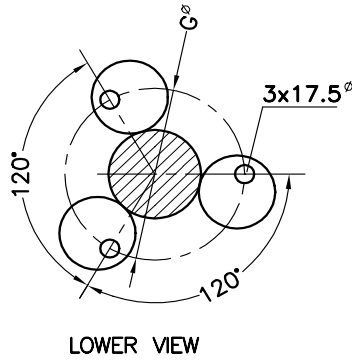
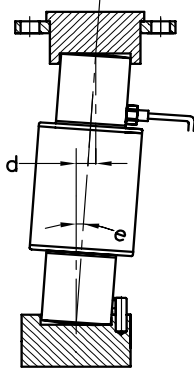

Load cells Wägezellen	A	B	C	D $\emptyset$	E $\emptyset$	F	G	H	d	e max. Max. Neigung	Radius Ball r	Transport- gewicht
740 100 t	340	147	120	64	104	100	165	17	18	4°	290	11 kg
740 200 t	340	147	120	64	104	100	165	17	9	2°	400	11 kg
740 400 t	400	220	190	109	140	160	200	21	8	1.4°	700	23 kg
740 600 t	440	220	190	118	140	160	200	21	8	1.4°	800	27 kg
Acc.74904	-	-	-	-	-	-	-	-	-	-	-	7 kg
Acc.74911	-	-	-	-	-	-	-	-	-	-	-	27 kg
Acc.74912	-	-	-	-	-	-	-	-	-	-	-	36 kg

Dimensions in mm. Abmessungen in mm.

SPECIFICATIONS			TECHNISCHE DATEN
Nominal capacities (Ln)	100-200- 400-600	t	Nennlasten (Ln)
Accuracy class	1000	n. OIML	Genauigkeitsklasse
Minimum dead load	0	%Ln	Minimale Vorlast
Service load	120	%Ln	Gebrauchslast
Safe load limit	150	%Ln	Grenzlast
Total error	< $\pm 0.05$	%Sn	Zusammengesetzter Fehler
Repeatability error	< $\pm 0.01$	%Sn	Wiederholgenauigkeit
Temperature effect: on zero	< $\pm 0.01$	%Sn/5 °C	Temperaturfehler: Nullpunkt
on sensitivity	< $\pm 0.018$	%Sn/5 °C	Kennwert
Creep error (30 minutes)	0.048	%Sn	Kriechfehler (30 min)
Temperature compensation	-10...+40	°C	Nenntemperaturbereich
Temperature limits	-50...+80	°C	Arbeitstemperaturbereich
Nominal sensitivity (Sn)	2 $\pm 0.5\%$	mV/V	Nennkennwert (Sn)
Nominal input voltage	10	V	Nom. Speisespannung
Maximum input voltage	15	V	Max. Speisespannung
Input impedance	800 $\pm 5$	$\Omega$	Eingangswiderstand
Output impedance	705 $\pm 5$	$\Omega$	Ausgangswiderstand
No load output	$\pm 2$	%Sn	Nullsignaltoleranz
Insulation resistance	> 5000	M $\Omega$	Isolationswiderstand
Maximum deflection (at Ln)	1.2-2.6	mm	Nennmessweg (bei Ln)

ELECTRICAL CONNECTION  
ELEKTRISCHER ANSCHLUSS:

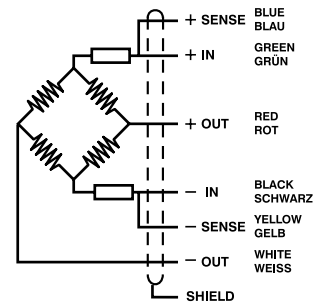

«SENSES»: 2 additional wires to maintain a constant voltage supply at the load cell when used with proper instrumentation. Use specially when long wires and wide temperature range.

SHIELD: Not connected to transducer body.

"SENSE-Leitung": zwei zusätzliche Adern, um eine konstante Spannungsversorgung an der Wägezelle zu gewährleisten, wenn entsprechende Elektronik verwendet wird. Speziell bei langen Leitungen und grossem Temperaturunterschied auf der Leitung.

SCHIRM: nicht am Wägezellenkörper angeschlossen.

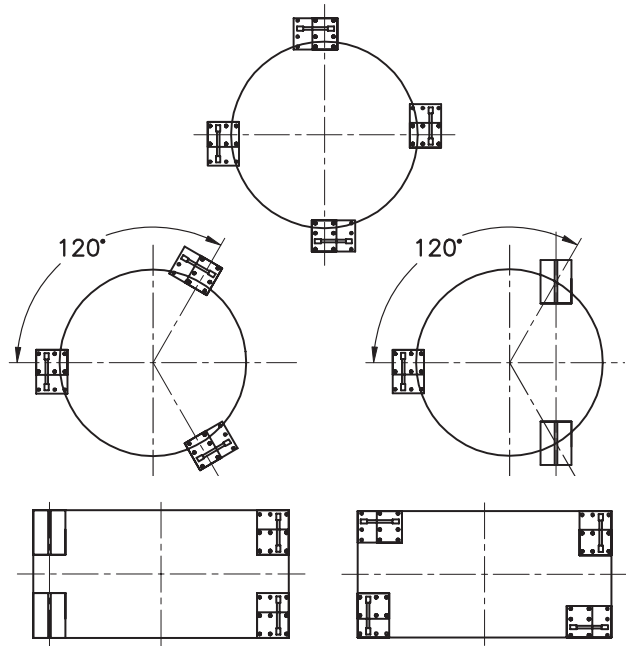
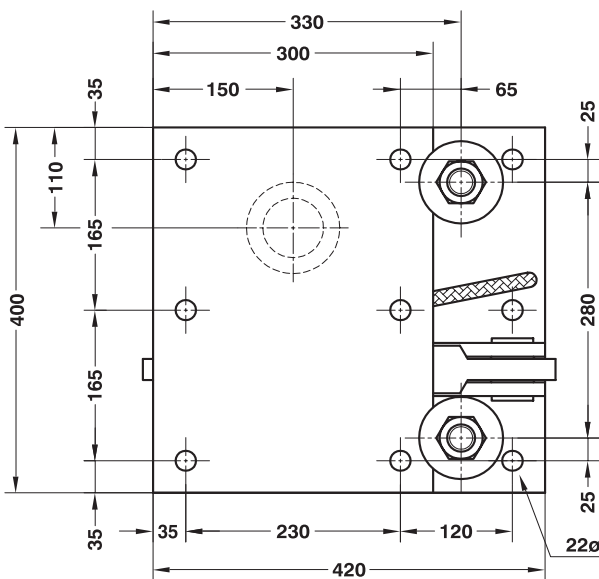
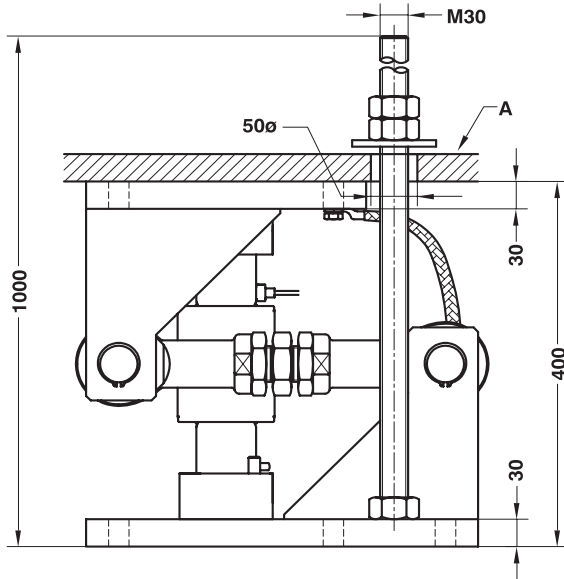
**MOUNTING KIT LIFT-OFF PREVENTION FOR SILO FOR M.740 (100...200t)**  
**LASTECKE MIT ABHEBESICHERUNG FÜR M.740 (100...200t)**

Nominal load	100...200 t	<i>Nennlast</i>
Max. permissible side offset transverse to retention arm	±5 mm	<i>Max. zulässige Seitenverschiebung zur Lenkerrichtung</i>
Permissible horitz. force in direction of the retention arm	180 kN	<i>Max. zulässige Horizontalkraft zur Lenkerrichtung</i>
Maximum permissible lifting force	228 kN	<i>Max. zulässige Zugkraft vertikal</i>
Max. permissible lifting movement, must be adjusted (A)	3 mm	<i>Max. zulässiger Nennweg vertikal, muss eingestellt werden (A)</i>
Material: Alloy Steel zinc-plated		<i>Material: Verzinkter Stahl</i>

 Dimensions in mm. *Abmessungen in mm.*

 Transport weight - *Transportgewicht:* 98 kg

# MOUNTING KIT LIFT-OFF PREVENTION FOR SILO FOR M.740 (400t) LASTECKE MIT ABHEBESICHERUNG FÜR M.740 (400t)

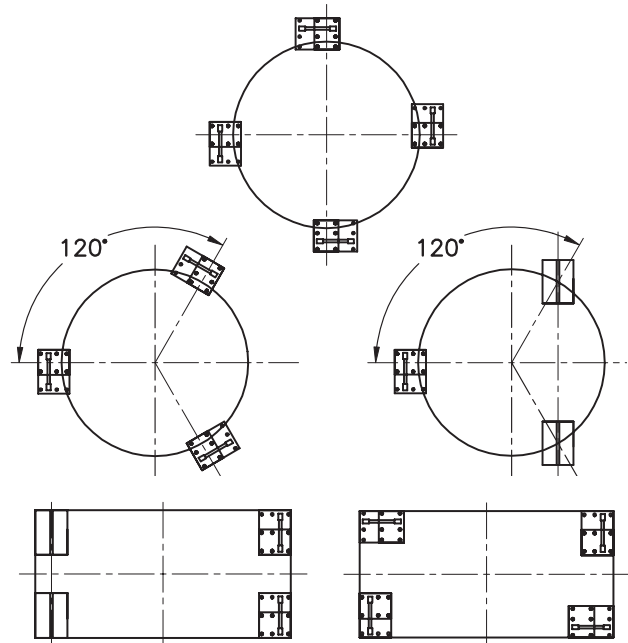
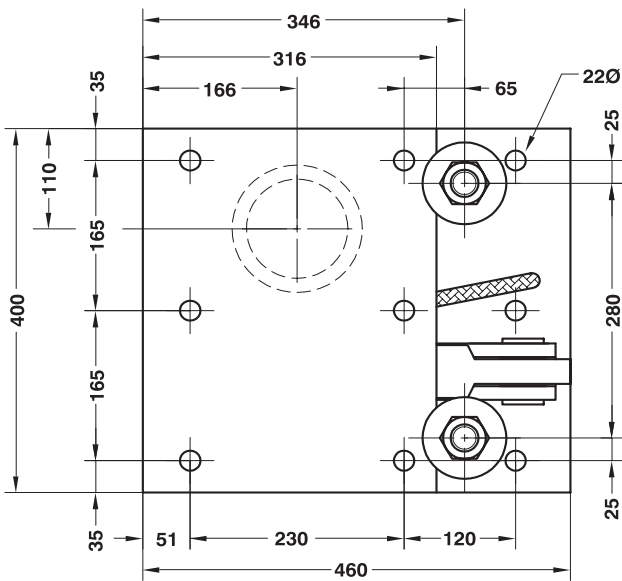
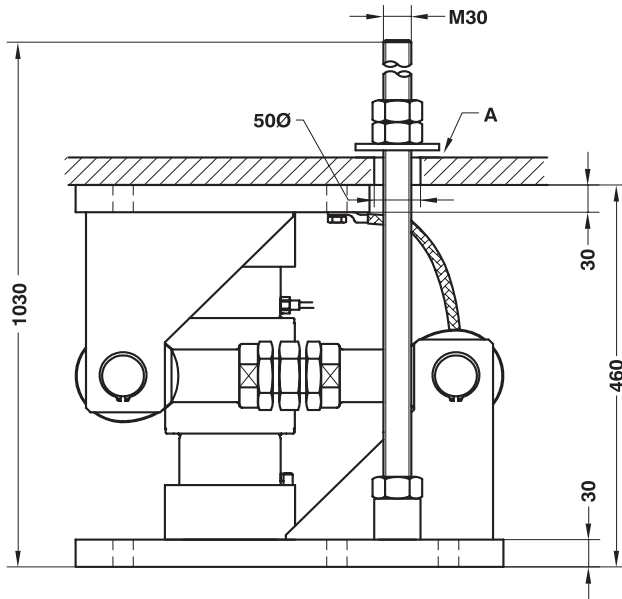

Nominal load	400 t	<i>Nennlast</i>
Max. permissible side offset transverse to retention arm	±5 mm	<i>Max. zulässige Seitenverschiebung zur Lenkerrichtung</i>
Permissible horitz. force in direction of the retention arm	240 kN	<i>Max. zulässige Horizontalkraft zur Lenkerrichtung</i>
Maximum permissible lifting force	330 kN	<i>Max. zulässige Zugkraft vertikal</i>
Max. permissible lifting movement, must be adjusted (A)	3 mm	<i>Max. zulässiger Nennweg vertikal, muss eingestellt werden (A)</i>
Material: Alloy Steel zinc-plated		<i>Material: Verzinkter Stahl</i>

Dimensions in mm. *Abmessungen in mm.*

Transport weight - *Transportgewicht:* 142 kg

# MOUNTING KIT LIFT-OFF PREVENTION FOR SILO FOR M.740 (600t) LASTECKE MIT ABHEBESICHERUNG FÜR M.740 (600t)

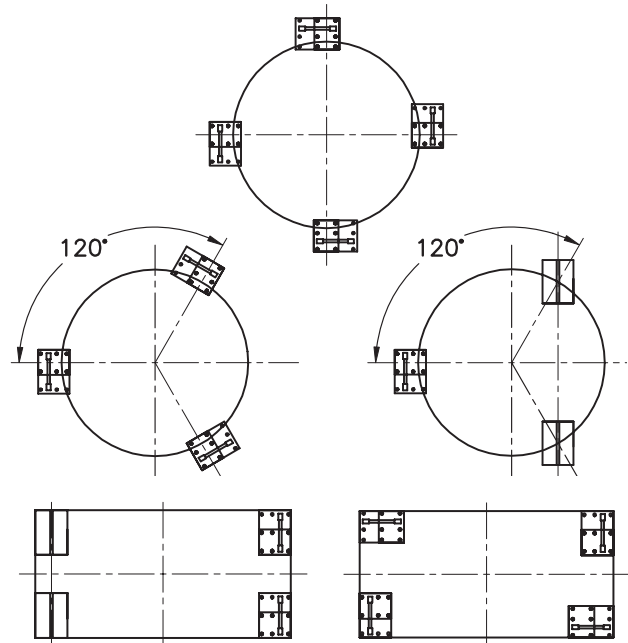
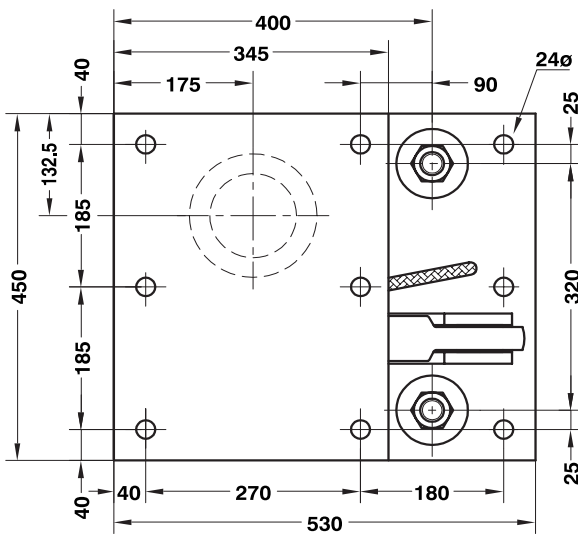
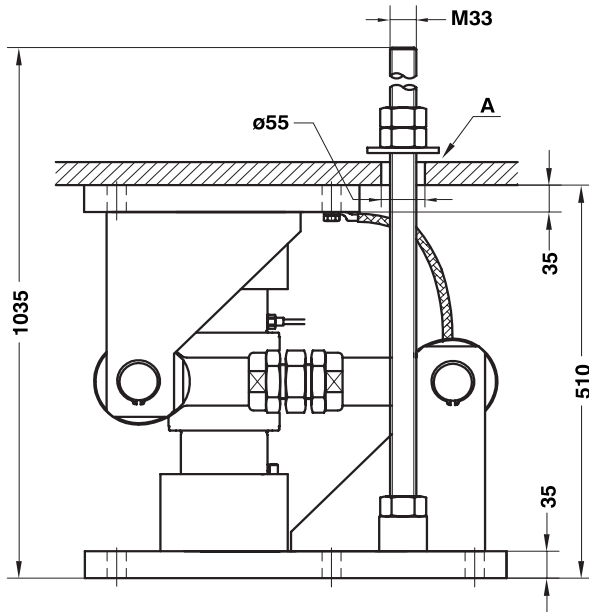

Nominal load	600 t	Nennlast
Max. permissible side offset transverse to retention arm	±5 mm	Max. zulässige Seitenverschiebung zur Lenkerrichtung
Permissible horitz. force in direction of the retention arm	290 kN	Max. zulässige Horizontalkraft zur Lenkerrichtung
Maximum permissible lifting force	395 kN	Max. zulässige Zugkraft vertikal
Max. permissible lifting movement, must be adjusted (A)	3 mm	Max. zulässiger Nennweg vertikal, muss eingestellt werden (A)
Material: Alloy Steel zinc-plated		Material: Verzinkter Stahl

Dimensions in mm. Abmessungen in mm.

Transport weight - Transportgewicht: 185 kg